



---

## **User Manual**

Document CC08106

---

### **Shelf Manager for:**

FlexChassis ATCA-SH141 (14-slot, 40G)

Continuous Computing  
9450 Carroll Park Drive  
San Diego, CA 92121-2256  
858-882-8800  
[www.ccpu.com](http://www.ccpu.com)

© 2001-2010 Continuous Computing Corporation. All rights reserved.

The information contained in this document is provided “as is” without any express representations of warranties. In addition, Continuous Computing Corporation disclaims all implied representations and warranties, including any warranty of merchantability, fitness for a particular purpose, or non-infringement of third party intellectual property rights.

This document contains proprietary information of Continuous Computing Corporation or under license from third parties. No part of this document may be reproduced in any form or by any means or transferred to any third party without the prior written consent of Continuous Computing Corporation.

Continuous Computing, the Continuous Computing logo, Create | Deploy | Converge, Embedded Solution Partners, The Embedded Solution Experts, Flex8, Flex21, FlexChassis, FlexCompute, FlexCore, FlexDSP, FlexPacket, FlexStore, FlexSwitch, FlexTCA, Quick!Start, TAPA, Trillium, Trillium+plus, the Trillium logo, and upSuite are trademarks or registered trademarks of Continuous Computing Corporation. Other names and brands may be claimed as the property of others.

The information contained in this document is not designed or intended for use in human life support systems, on-line control of aircraft, aircraft navigation or aircraft communications; or in the design, construction, operation or maintenance of any nuclear facility. Continuous Computing Corporation disclaims any express or implied warranty of fitness for such uses.

# Table of Contents

Table of Contents.....	3
Figures .....	4
Tables .....	5
Related Documents.....	6
1.    Safety.....	7
1.1. General Safety Practices .....	7
1.2. Working with Lithium Batteries.....	7
2.    Introduction .....	8
2.1. ATCA Shelf Manager Board.....	8
2.2. Shelf Manager Board Components.....	9
2.3. Features .....	9
2.4. Front Panel.....	10
3.    Understanding the Board Components .....	11
3.1. Visual Indicators.....	11
3.2. External Connections .....	12
3.2.1. Telco Alarm Connector.....	12
3.2.2. Serial RS232 (Console) Connector .....	13
3.2.3. Ethernet Connector.....	13
3.3. Jumpers.....	13
4.    Understanding the Board Components .....	15
4.1 Inserting the Shelf Manager board.....	15
4.2. Shelf manager Board Battery Replacement .....	15
5.    Software Commands .....	17
5.1. General.....	17
5.2. Console Connection.....	17
5.3. Management Commands.....	18
6.    Acronyms .....	20

# Figures

<b>I.D.</b>	<b>Figure</b>	<b>Page</b>
1	Block Diagram of Shelf Manager Board	9
2	Board Layout	9
3	Front Panel	10
4	LEDs on the shelf manager Board Front Panel	11
5	Shelf Interconnect	14
6	Shelf Manager Board Insertion	15
7	Battery Isolation Film	15
8	The HyperTerminal screen	18
9	Serial Port Configuration Screen	18

# Tables

<b>I.D.</b>	<b>Table</b>	<b>Page</b>
1	General LEDs	11
2	Telco Alarm LEDs	11
3	Application-Defined LEDs	12
4	Telco Alarm Connector	12
5	Serial RS232 (Console) Connector	13
6	Ethernet Connector	13

# About this Document

This document provides technical information for the 14-slot ATCA-SH141 Shelf Manager Board (ShMC). It is intended for technical staff tasked with installing, setting up and configuring the system, and providing troubleshooting assistance and servicing.

## Related Documents

Instructions relating to software installation and documentation for application software development for this platform are available in the Shelf Manager External Interface Reference Manual provided by Pigeon Point Systems - <http://www.pigeonpoint.com/>.

For Continuous Computing product information and additional resources, please visit the Continuous Computing website at <http://www.ccpu.com/>.

Downloads (manuals, release notes, software, etc.) are available via the Technical Support Library product links at <http://www.ccpu.com/customer-support/downloads-documentation/> (for registered customers).

Information about PICMG (PCI Industrial Computer Manufacturers Group) and the ATCA standard may be accessed on the PICMG Web site at [www.picmg.com](http://www.picmg.com).

# 1. Safety



This symbol indicates potential safety hazards regarding product operation or maintenance to operator or service personnel.

## 1.1. General Safety Practices

Before handling the board, read the instructions and safety guidelines on the following pages to prevent damage to the product and to ensure your own personal safety.

- Always use caution when handling/operating the board. Only qualified, experienced, authorized electronics service personnel should access the interior of the equipment.
- Always follow the procedural instructions for component removal and replacement in sequence.

## 1.2. Working with Lithium Batteries

Your computer board may have a non-rechargeable lithium battery.

- Do not short circuit
- Do not heat or incinerate
- Do not charge
- Do not deform or disassemble
- Do not apply solder directly
- Do not mix different types or partially-used batteries together
- Always observe proper polarities.

## **2. Introduction**

### **2.1. ATCA Shelf Manager Board**

The ATCA FlexChassis shelf is designed to comply with all relevant ATCA specifications, including the IPMI 1.5 (Intelligent Platform Management Interface) specifications.

The ATCA Shelf Manager Board monitors the shelf temperature sensors, collects status information, generates alarms, and controls the indication displays and the fan trays.

It's remote control capable. It supports multiple management interfaces, including: RMCP, RPC, SNMP, CLI and Web Interface.

## 2.2. Shelf Manager Board Components

Figure 1: Block Diagram of Shelf Manager Board

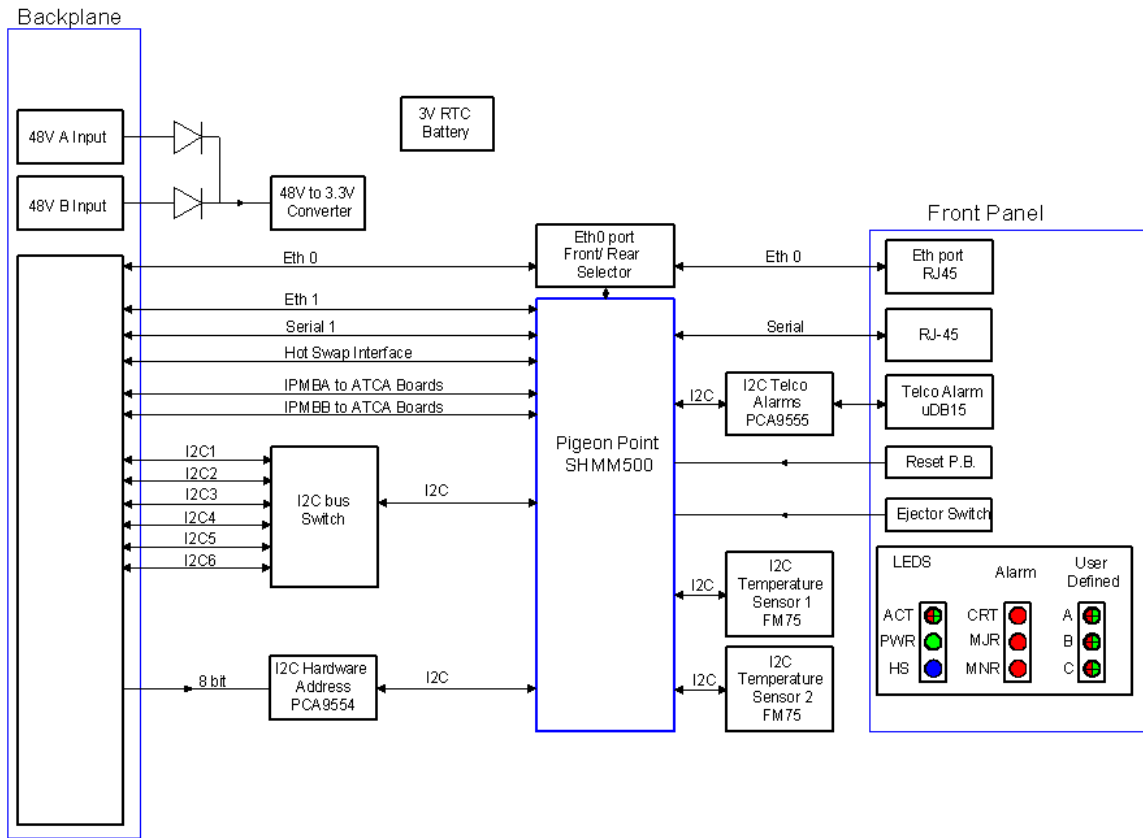
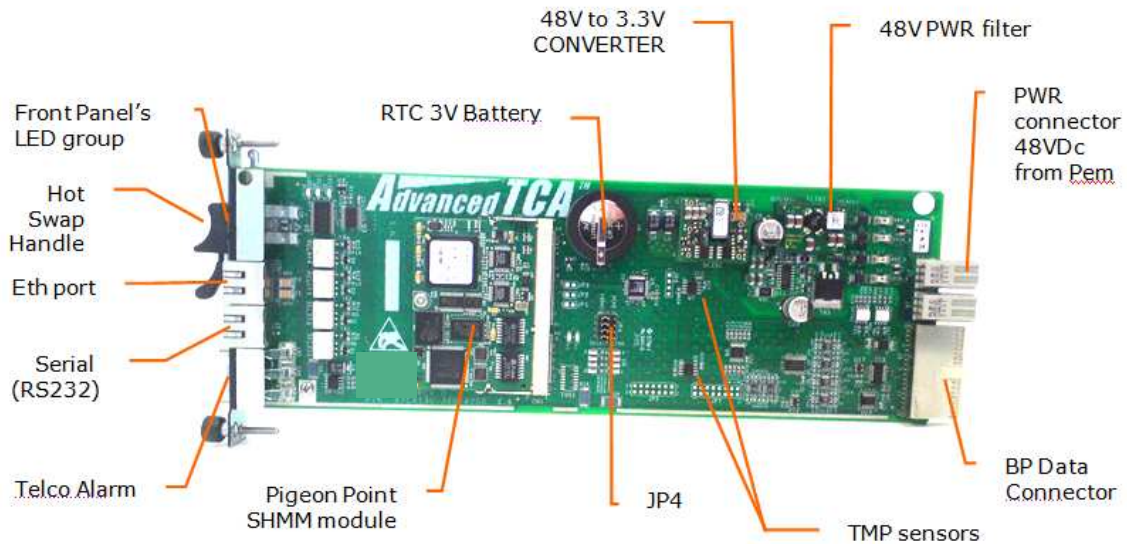

Figure 2: Board Layout



## 2.3. Features

The Shelf manager Board is a FRU with the following features and functionality:

- Fan tray control – controlling the fan trays thru the IPMB
- Providing 3.3V to other parts of the board

- Intake air temperature monitoring
- D-Type 9 pin serial port
- LED Alarms display
- Telco Alarms control and display
- Hosting of the Pigeon point ShMM500 management module
- Front Ethernet connection.
- Rear Ethernet connection
- RJ45 Serial Support
- Reset button
- Hot swap capability with hot swap handle

## 2.4. Front Panel

The Shelf Manager board's front panel contains the display as shown in figure 3:

**Figure 3: Front Panel**

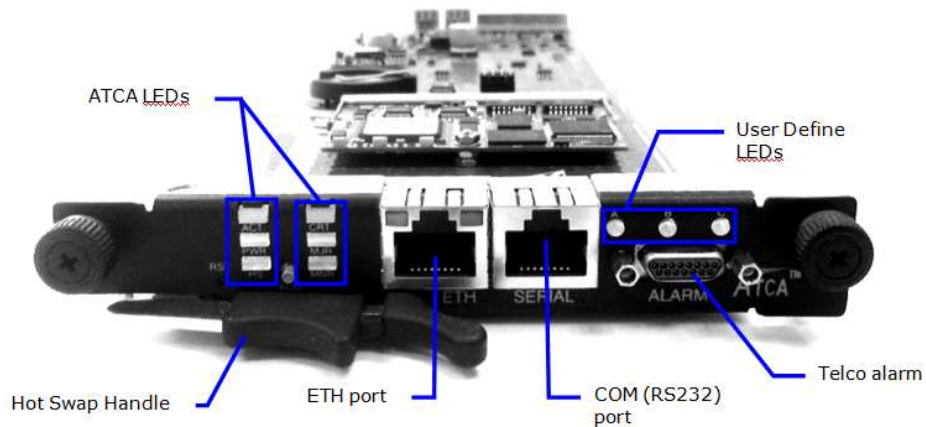

# 3. Understanding the Board Components

This chapter summarizes the functional features and components of the board.

The board was designed to withstand extreme conditions (to meet rigid Telco requirements). It is a Field-Replaceable Unit (FRU), and is fully field-serviceable.

## 3.1. Visual Indicators

The front panel of the shelf manager board features nine LEDs arranged in three groups:

- o General LEDs
- o Alarm LEDs
- o Application-defined LEDs.

### 3.1.1. Boot-up LED Status

At Power up all LED's light up for about 40 seconds during shelf manager board boot-up.

**Figure 4: LEDs on the shelf manager Board Front Panel**

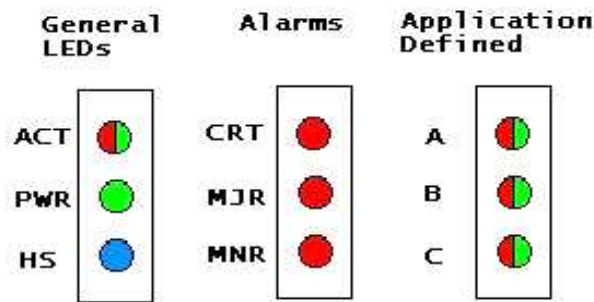

### 3.1.2. LED Functions: General LEDs

**Table 1: General LEDs**

LED	Status	Meaning
ACT	Green	Shelf Manager Board active
	Red	Shelf Manager Board failure
	Blink	Shelf Manager Board inactive
PWR	Green	Local voltage supply on Shelf Manager board
	Off	Local voltage failure
HS (Hot Swap)	Steady Blue	Shelf Manager Board powering up or ready for extraction
	Blinking Blue	Shelf Manager Board hot swap process
	Off	Shelf Manager Board operating

**Table 2: Telco Alarm LEDs**

LED	Status	Meaning
CRT (Critical)	Off	Normal operation
	Red	System alarm event
MJR (Major)	Off	Normal operation
	Red	System alarm event
MNR (Minor)	Off	Normal operation
	Red	System alarm event

**Table 3: Application-Defined LEDs**

LED	Status	Meaning
A	Green/ red/ bi-color	As defined by application
B	Green/ red/ bi-color	As defined by application
C	Green/ red/ bi-color	As defined by application

Upon completion of boot-up, LEDs will display as follows:

General LEDs		Telco Alarm LEDs	Application Defined LEDs
ACT	Reverts to normal role	OFF	OFF
PWR	Remains ON		
HS	Lights steady blue for a few seconds, then begins blinking, then goes off after a few blinks		



When a user-defined dual color LED is on and colored green and red (as during boot-up), the visible color is **orange**.

## 3.2. External Connections

The Shelf Manager Board features three connectors on its front panel. A pin-out description of each connector is provided in this section.

### 3.2.1. Telco Alarm Connector

The Telco Alarm Connector is a mini-D type 15 pin connector with the following pin definition:

**Table 4: Telco Alarm Connector**

Pin	Signal Name
1	Minor Reset Plus
2	Minor Reset Minus
3	Major Reset Plus
4	Major Reset Minus
5	Critical Alarm -NO
6	Critical Alarm -NC
7	Critical Alarm -COM
8	Minor Alarm – NO
9	Minor Alarm – NC
10	Minor Alarm – COM

11	Major Alarm – NO
12	Major Alarm – NC
13	Major Alarm – COM
14	Power Alarm – NO
15	Power Alarm -COM

### 3.2.2. Serial RS232 (Console) Connector

The Serial RS232 (Console) connector is a RJ 45, DTE serial port with the following pin-out definition, looking form the front the first pin is on the left:

**Table 5: Serial RS232 (Console) Connector**

Pin	Signal Name	Description
1		not connected
2		not connected
3	TxD	Out Transmit Data
4	SGND	Signal Ground
5	SGND	Signal Ground
6	RxD	In Receive Data
7		not connected
8		not connected

### 3.2.3. Ethernet Connector

The Ethernet connector is a standard RJ-45 jack with the following pin-out definition, looking form the front the first pin is on the left:

**Table 6: Ethernet Connector**

Pin	Signal Name	Description
1	TxD+	Out Transmit Data Plus
2	TxD-	Out Transmit Data Minus
3	RxD+	In Receive Data Plus
6	RxD-	In Receive Data Minus

The following is indicated by the Ethernet connector LED's:

- Green – Line activity;
- Yellow – 100Mbs.

## 3.3. Jumpers

The jumper is used to select the connection of the Ethernet 0 port either to the Shelf manager board's front panel, or to the backplane.

The jumper, located on the Shelf Manager card, is marked: **JP4**.

**JP4** selects the connectivity between the Front panel and backplane access.

All four connectors must be connected to the same position (pins 1-2 or 2-3) and they function as follows:

- Jumpers connected between pins 1-2: the front connection is active
- Jumpers connected between pins 2-3: the rear connection is active.

**Figure 5: Shelf Interconnect**

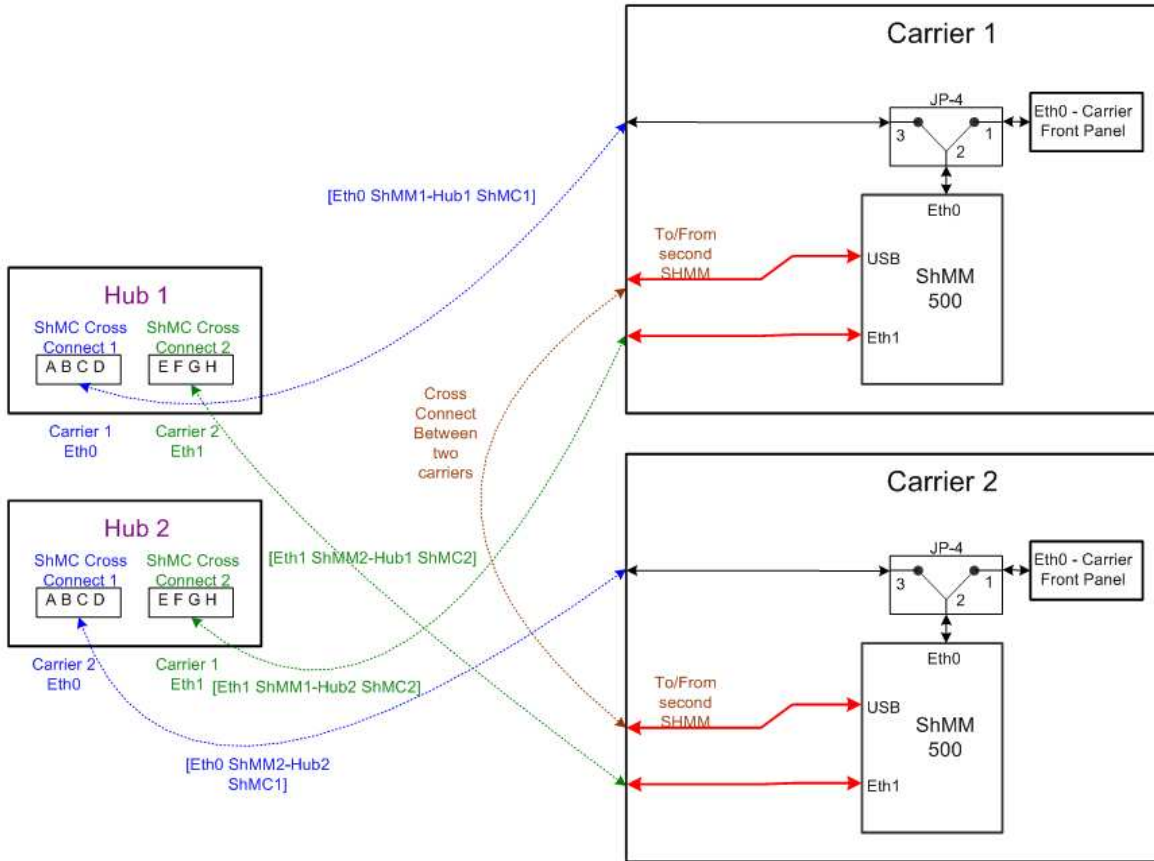

## 4. Understanding the Board Components

### 4.1 Inserting the Shelf Manager board

→ **To insert the shelf manager board:**

1. Carefully Insert the Shelf Manager card on the slot, making sure Inserting the insertion lever into the right position and that it plugs firmly into it's place.
2. Fasten the locking screws on both top & bottom of the board's front panel.
3. Make sure that after about 40 seconds the blue led (hot swap) is off.

**Figure 6: Shelf Manager Board Insertion**

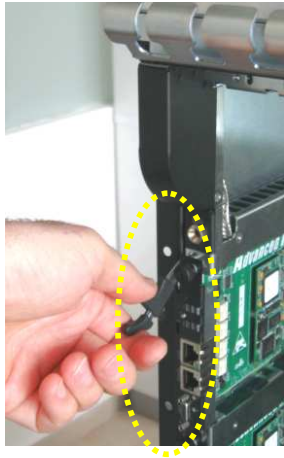

### 4.2. Shelf manager Board Battery Replacement

The Shelf Manager Board contains a lithium battery. There is a danger of explosion if the battery is incorrectly replaced or handled.



Do not disassemble or recharge the battery. Do not dispose of the battery in fire. When the battery is replaced, the same type or an equivalent type recommended by the manufacturer must be used. Used batteries must be disposed of according to the manufacturer's instructions.

→ **Removal of the battery isolation film:**

The isolation film protects the battery and saves its energy prior to using it. Before using a brand new Shelf Manager, remove the isolation film. See figure 7.

1. Lift the battery clamp and remove the isolator.
2. Release the clamp.

**Figure 7: Battery Isolation Film**

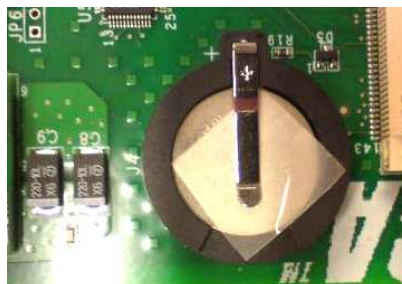

→ **To replace battery:**

1. Lift the battery clamp and remove the old battery.
2. Insert a new CR2016 lithium battery.
3. Release the clamp.

The battery exchange must be completed within less than **one minute**.

**Battery Backup Characteristics**

Battery Voltage: 3V

Battery Capacity: 48mAh

Power applied for 24 hours per day

Electrochemical Construction:

Long-life lithium with solid-state cathode.

# 5. Software Commands

## 5.1. General

The Shelf manager Board contains software necessary to manage the shelf and communicate with the intelligent management control software from an external console.

The external interfaces supported include:

- A command-line interface (CLI).
- A WEB interface.
- A Simple Network Management Protocol (SNMP) interface.
- A Remote Management Control Protocol (RMCP) interface.
- A Remote Procedure Call Protocol (RPC) interface

Administrators can access the shelf to retrieve information on the current status of the shelf, including:

- Current FRU population.
- Current sensor values.
- Threshold settings.
- Recent events.
- Overall shelf health.

Please refer to *Pigeon Point's Shelf Management External Interface Reference Manual* for further details on programmatic interface with the shelf.

## 5.2. Console Connection

A dumb terminal or a PC with terminal-emulation software should be connected to the RS232 **Console** port on the active Shelf manager board.

Serial D type 9 pin female to RJ45 communications cable is required.



When a PC terminal emulator is used, the communication cable should be connected to a free communications port (COM1 or COM2), and the connection should be defined in the HyperTerminal program (see Figure 8).

Figure 8: The HyperTerminal screen



The following parameters should be defined in the **Port Settings** tab of the **COM Properties** dialog, see Figure 9:

Figure 9: Serial Port Configuration Screen

Bits per second  
Parity  
Stop bits  
Flow control.



### 5.3. Management Commands

At start-up, the Shelf Management program requires user identification. The default login name is: root with no password.

After login, the following screen will be displayed in the console (**Terminal**) window:



## 6. Acronyms

<b>Acronym</b>	<b>Meaning</b>
ATCA	Advanced Telecom Computing Architecture
FRU	Field-Replaceable Unit
HS	Hot Swap
PEM	Power Entry Module
IPMB	Intelligent Platform-Management Bus
IPMI	Intelligent Platform-Management Interface
RTM	Rear Transmission Module
ShMC	Shelf Manager board
NEBS	Network Equipment-Building Systems
ETSI	European Telecommunications Standards Institute
ANSI	American National Standards Institute
CE	"Conformité Européene" ("European Conformity")
FCC	Federal Communications Commission
UL	Underwriters Laboratories - safety standards
CFM	Cubic Feet per Minute – Airflow measurement unit